

Maximum payload up to 80kg at 366cm.

Simultaneous extension and retraction of all sections.

All components inside transmission box are made of carbon-nitrided casehardened steel for improving wear resistance.



Parts made by die cast aluminum to ensure longer lasting mechanical performance and extension linearity of column.



Assembled using bolts instead of rivets for simpler maintenance.



Double braced legs for extra stability, resistance and safety.



All stands in this series can be equipped with wheels (including types with brakes).

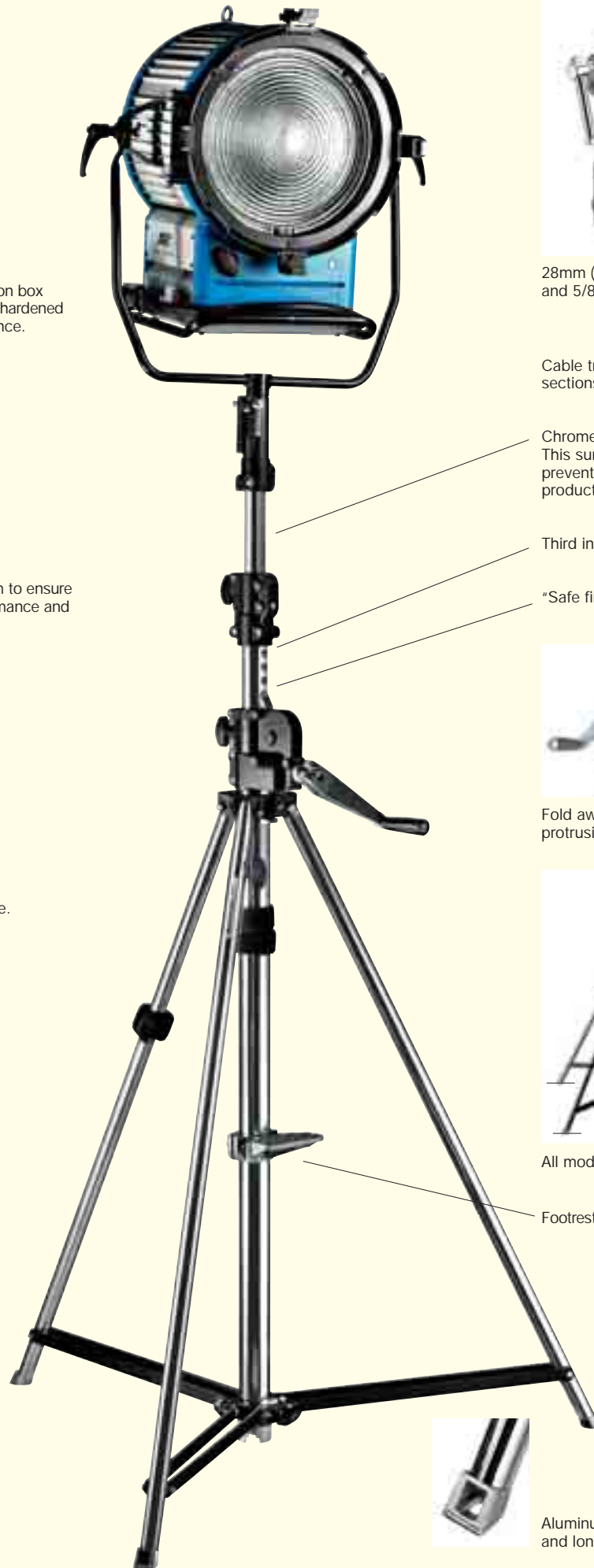

28mm (or 16mm) socket and 5/8" + 3/8" stud.

Cable transmission is fully inside sections.

Chrome-plated steel tubing. This surface finishing lasts longer, prevents oxidation and gives the product a polished look.

Third internal safety cable.

"Safe finger" protection.



Fold away crank handle for reducing protrusions during storage.



All models feature leveling leg.

Footrest for easy access to top section.



Aluminum feet for improved stability and longer durability.



2 SCT LOW BASE WIND-UP STAND 083NWL B



129cm 190cm 112cm 100cm 11kg



35kg 2,5kg@190cm Type 14

Geared centrepost steel stand.
2 sections, 1 riser.
Ø: 55, 45mm.
1 levelling leg.
Fitted with braked wheels.



2 SCT WIND-UP STAND 083NW



139cm 247cm 153cm 128cm 16kg



45kg 30kg@247cm Type 14 104, 104G, 374-10

Chrome steel stand with geared column.
Elevation: 2.2cm per handle turn.
2 sections, 1 riser.
Ø: 55, 45mm.
Leg Ø: 30mm.
1 levelling leg.



3 SCT LOW BASE WIND-UP STAND 087NWL B



144cm 276cm 134cm 100cm 16kg



30kg 5,5kg@276cm Type 14

Geared centrepost steel stand.
3 sections, 2 risers.
Ø: 55, 45, 38mm.
1 levelling leg.
Fitted with braked wheels.

SHORT WIND-UP STAND 087NWSH

 135cm
  276cm
  155cm
  128cm
  15,5kg

 30kg
  15kg@276cm
  Type 14
  104, 104G, 374-10

Short version of 087NW.
 3 sections, 2 risers.
 Ø: 55, 45, 38mm.
 Leg Ø: 30mm.
 1 levelling leg.



WIND-UP STAND 087NW

 167cm
  370cm
  181cm
  128cm
  21,4kg

 30kg
  30kg@370cm
  Type 14
  104, 104G, 374-10

Chrome steel stand with geared column.
 2 risers extend simultaneously at
 an elevation of 4.4cm per handle turn.
 Safety cable ensures simultaneous
 retrieval of all sections.
 3 sections, 2 risers.
 Ø: 55, 45, 38mm. Leg Ø: 30mm.
 1 levelling leg.



SUPER WIND-UP STAINLESS STEEL STAND 387XU



156cm



366cm



179cm



180cm



32,5kg



80kg



80kg@366cm



28mm



374

Heavy lift stand with strengthened stainless steel column and legs, chrome steel risers and geared column. 3 section Ø: 70, 60, 50mm. 2 risers which extended simultaneously at 4.4cm per handle turn. Safety cable ensures simultaneous retrieval of all sections. Rapid adjustment. Leg Ø 35mm. 1 levelling leg. PATENTED

